

250 W VHF/FM Transposer TP3281

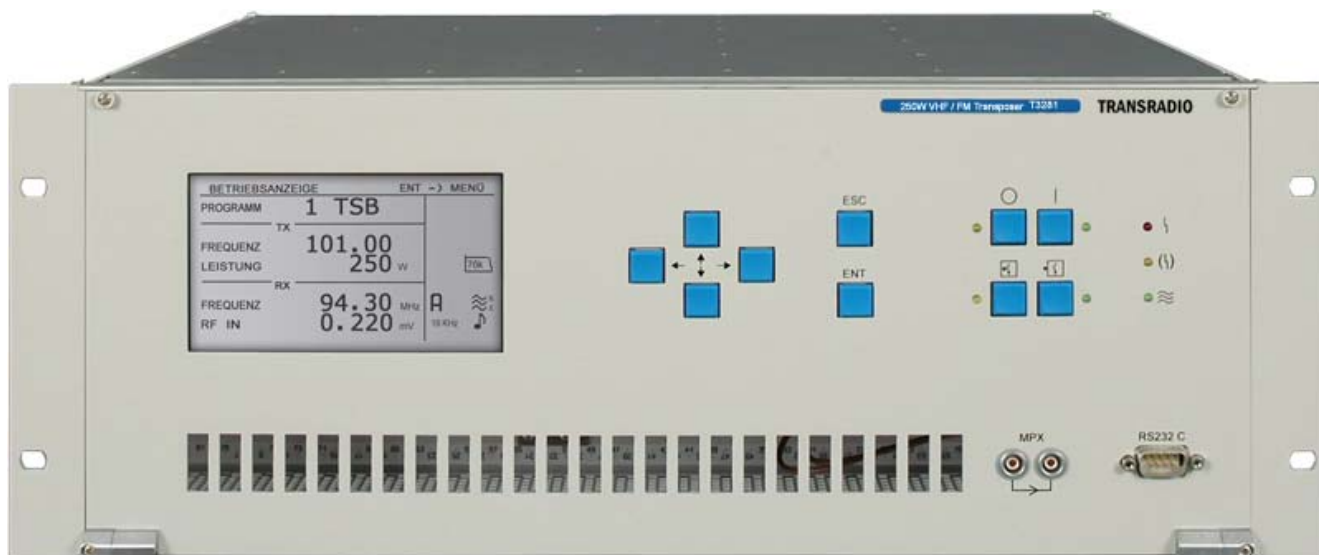

Highlights of the VHF/FM Transposer TP3281

- Double super heterodyne receiver with large high-level signal stability
- The very high dynamic selection allows, even under difficult receiving conditions, e.g., due to strong adjacent frequencies, an interference-free reception, so that in many cases one can do without additional expensive band filters
- The high sensitivity allows interference-free reception even under low field strength conditions
- Full electronic tuning of the receiver- and transmitter sections
- Simple and intuitive menu control via a large graphic display
- Service friendly design with plug-in Eurocard modules
- 19" slide-in technology of height 4 U
- All important functions and status information of the receiver- and transmitter sections are simultaneously shown on the graphic display
- Prepared for all reserve concepts
- Proven MOSFET technology
- Excellent reliability due to low junction temperatures of $< 90^{\circ} \text{C}$ at T (ambient) = 25°C
- Very good quality data in with respect to unweighted- and weighted S/N ratio, stereo crosstalk, frequency response and non-linear distortion
- Protective circuits against overvoltage, fan failure, overtemperature and mismatch
- RF output power continuously adjustable between 50 W and 250 W in 1 W steps

Application

The VHF/FM Transposer TP3281 can provide cost effective coverage of broadcast programs to difficult accessible regions, e.g. valleys in the shadow of mountains, without high investment. The transposer can also be used as an exciter for transmitters of higher power class.

The VHF/FM transposer demodulates the received signal to the MPX level. In the downstream transmitter section the new transmitting frequency is modulated with this MPX signal. The receiver- and transmitter frequencies are precisely set by means of two synthesizers.

Up to six pre-programmable settings, including all associated program specific operating values, such as receiver frequency, transmitter frequency, and RF mute threshold as well as RF output power can be called for an n+1 system. A receiver frequency diversity circuit expands the operating capabilities of the unit.

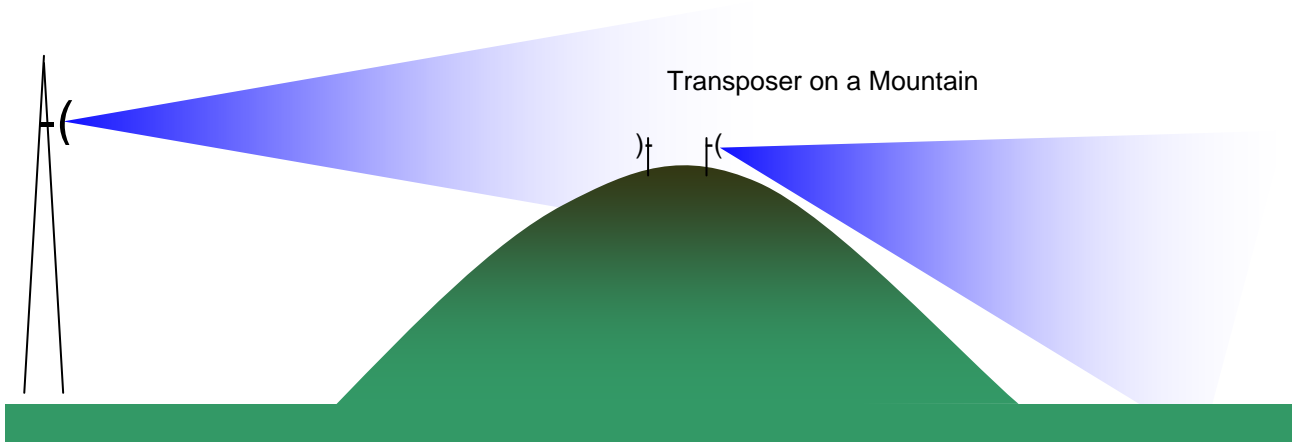

Operating Principle of the Transposer

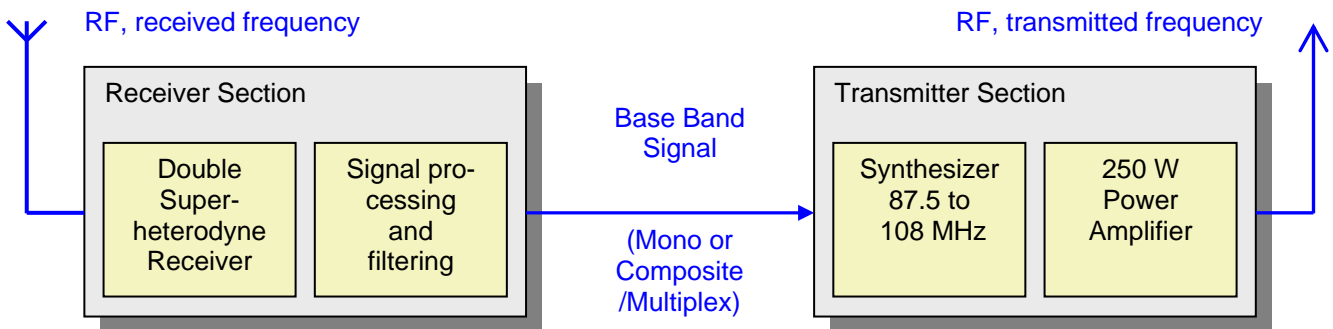

Block Schematic of the Transposer

The VHF/FM Transposer fulfils the national and European standards as well as the technical specifications of the ARD (5/3.5), the Deutschen Telekom (TS 0220/96) and the Swisscom (42SO_0049d).

Technical Data

RF output connector	N, 50 Ω
Antenna input	BNC, 50 Ω
Remote interfaces	Standard: RS232 Option: Relay, BITBUS, SNMP or HTTP
Operating mode (freely selectable)	Mono, stereo, (L+R)/2
Number of preset frequencies	6
MPX separation between receiver- and transmitter parts	LEMO-Triaxial
Cooling	Internal fan
Operational in the temperature range	- 10° C ... + 50° C
Humidity	to 95 %, without dew
Dimensions W x H x D in mm	483 x 177 x 370
Weight	16 kg

Power Supply

Voltage range	1/N/PE 115 V	85 V ... 132 V
	1/N/PE 230 V	176 V ... 264 V
Mains frequency		47 Hz ... 63 Hz
Power consumption		535 W at P _{RF} = 250 W
cos φ		> 0.7
Ready after mains failure		< 2 sec

Receiver Section

Frequency range	87.5 MHz ... 108 MHz, adjustable in 1 kHz steps
Middle frequency drift	+/- 300 Hz
1. intermediate frequency	10.7 MHz
2. intermediate frequency	700 kHz
MPX test signal output	SMB, 50 Ω

Selection with Stereo	+/- 6 kHz	> -60 dBc
	+/- 100 kHz	> -60 dBc
	+/- 200 kHz	> 0 dBc
	+/- 300 kHz	> +25 dBc

Selection is a measure of the immunity against a RF interferer whose frequency lies close to the receiver frequency. It is defined as the largest allowed level of an interferer relative to the receiver signal („carrier“), in which a weighted S/N ratio of > 54 dB, referred to 40 kHz deviation, is adhered to. The interferer is modulated with 500 Hz and 75 kHz deviation. The measurements are carried out at a receiver level of 1mV_{rms} = 43 dB (pW) = 60 dBμV = - 47 dBm.

High-level Signal Noise Immunity with Stereo > +30 dBc

The High-level signal noise immunity is a measure of the immunity against two RF interferers, lying 1.5 MHz symmetrically about the receiver frequency. It is defined as the largest allowed level of these interferers relative to the receiver signal („carrier“), in which a weighted S/N ratio of > 54 dB, referred to 40 kHz deviation, is adhered to. One of the interferers is modulated with 500 Hz and 75 kHz deviation. The measurements are carried out at a receiver level of von 1mV_{rms}.

Weighted S/N Ratio

Measured via a stereo encoder according to DIN 45405 (CCIR Rec. 468-2) referred to the output voltage at f_{mod} = 500 Hz and 40 kHz deviation

	Receiver level	
Unweighted S/N ratio (stereo)	1 mV _{rms} = 60 dBμV	> 67 dB
	10 mV _{rms} = 80 dBμV	> 70 dB
Weighted S/N ratio (stereo)	1 mV _{rms} = 60 dBμV	> 63 dB
	10 mV _{rms} = 80 dBμV	> 65 dB

Amplitude Deviation	40 Hz ... 43 kHz	± 0.1 dB
	43 kHz ... 65 kHz	± 0.3 dB
	65 kHz ... 76 kHz	± 0.4 dB

Distortion Factor , at 75 kHz deviation	40 Hz ... 5 kHz	< - 49 dB
	5 kHz ... 15 kHz	< - 43 dB

Transmitter Section

Transmitter Power

Output power P_{RF}	250 W
Output power setting range	50 W ... 250 W, continuous
Full power up to VSWR = 1.5	thereafter down regulation of output power

Frequency

Frequency range	87.5 MHz ... 108 MHz, in 10 kHz steps
Frequency change	< 1 sec
Frequency drift over 3 months	< 300 Hz
Setting accuracy	< 50 Hz
Middle frequency shift during modulation	0 Hz
Deviation instability	< 1 %
Warm-up time	< 5 min

Out-of-band Emission

0.2 MHz	< - 110 dBc/Hz
0.3 MHz	< - 126 dBc/Hz

Spurious Emission

Harmonic emissions	< - 80 dBc
Noise power density	< - 150 dBc/Hz

Reverse Intermodulation Products

> 15 dB

Linear Distortion

Stereo cross-talk attenuation	
40 Hz ... 15 kHz	> 45 dB
Amplitude deviation	
40 Hz ... 65 kHz	± 0.1 dB
> 65 kHz ... 76 kHz	± 0.2 dB
100 kHz	- 2 dB ± 0.5 dB
Damping of the 15 kHz low-pass	
40 Hz ... 15 kHz	< 0.2 dB
at 19 kHz	> 50 dB

Non-Linear Distortion

Distortion factor 40 Hz ... 15 kHz, at 75 kHz deviation	< 0.1 % = - 60 dB
---	-------------------

Selective S/N Ratio

Mono	> 80 dB
Stereo	> 80 dB

Unweighted S/N Ratio (effective peak value)

Mono	> 72 dB
Stereo	> 72 dB
AM unweighted S/N ratio, asynchronous	> 60 dB
AM unweighted S/N ratio, synchronous	> 60 dB

Weighted S/N Ratio (effective peak value)

Mono	> 70 dB
Stereo	> 70 dB
AM weighted S/N ratio, asynchronous	> 60 dB

Contact address:

TRANSRADIO SenderSysteme Berlin AG

Mertensstr. 63,
13587 Berlin, Germany

Telephone:

++49-30-339 78-0

Telefax:

++49-30-339 78-599

Email:

info@tsb-ag.de

Internet:

<http://www.transradio.de>