

**2,5kW VHF/FM SOLID STATE TRANSMITTER**

The 2,5 kW VHF/FM transmitter T3256 is designed for frequency modulated broadcasts, in mono or stereo, in the VHF frequency range of 87,5 to 108 MHz.

Power classes 5 kW and 10 kW are available in this concept too.

*2,5 kW VHF/FM transmitter*

**Features:**

- Solid state design utilizing TMOS FET's (transistors)
- Clearly arranged and easily accessible assemblies mounted in a 19" standard rack
- Exciter as synthesizer and control unit with  $\mu$ P-control
- Serial interface for remote control is standard, BITBUS interface optional
- High redundancy due to modular configuration
- Low junction temperatures ( $< 100\text{ }^{\circ}\text{C}$ ) of the RF power transistors
- Each amplifier disposes of its own primary power supply unit
- Control of mismatch and mains fluctuation via the primary power supply units
- Protective circuits for the RF power transistors providing foldback under high mismatch conditions allow a reliable operation
- Efficient low noise forced air cooling
- Internal blower
- Variety of intake and outlet solutions for forced air cooling

**Set-up:**

The 2,5 kW VHF/FM transmitter consists of following assemblies:

- Exciter VHF/FM transmitter T 3270
- 2.5 kW RF amplifier SV 3254
- primary power supply unit NG 3254
- Control unit CU 3254 with control panel and central computer

The assemblies are integrated in a rack, dimensioned 2000 x 600 x 1000 mm (H x W x D).

The transmitter is air cooled. All air in- and outlet lines can be connected either bottom/bottom, bottom/top or top/top.

The distinct switching power supply units assigned to the 2.5 kW RF amplifier stages guarantee high redundancy and operational reliability and constitute a well proven concept of our company for years.

The transmitter's modular set-up allows to accommodate in one rack either a 2,5 kW double transmitter in passive stand-by configuration, two single 5 kW transmitters or a 10 kW transmitter with dual exciter.

**Principles of Operation:**

The VHF/FM transmitter T 3270 of recent design will be used as exciter. Its performance characteristics determine the quality parameters of the transmitter as a whole.

In the 2,5 kW RF amplifier, the exciter power is routed via a driver amplifier and a 0° splitter to five 500 W amplifiers, which are connected in parallel and are summarized to 2.5 kW output power with a combined 5 :1 combiner-harmonic filter.

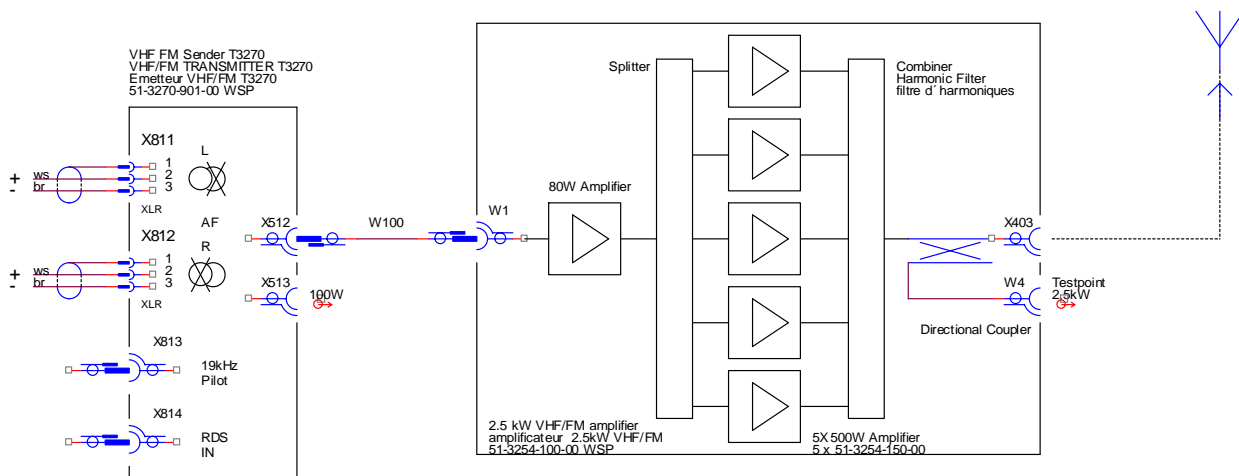

*Schematic 2,5 kW VHF/FM transmitter*

Directional couplers at the 2,5 kW Amplifier output, accommodating forward and reflected coupling loops, serves for RF power indication as well as for transmitter protection functions.

Under high mismatch conditions ( VSWR >1.5 : 1) the output power is leveled down (foldback) to an appropriate value not endangering the transistors. Switch off is not initiated. A free RF measuring point is available for measuring purposes. Continued operation at reduced power takes place when power transistors fail.

The control unit CU 3254 serves for the transmitter's operational, control and monitoring functions. It is microprocessor controlled. Operational conditions are indicated by LEDs and an LCD. For remote control, the control unit incorporates a V.24/RS232C interface or optionally a BITBUS interface.

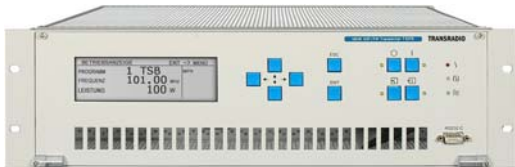

VHF/FM transmitter T 3270

**Technical Data:**

Frequency range	87.5 to 108 MHz
RF output	1-5/8"-EIA
RF output power	2,5 kW
RF output impedance	50 Ω
Harmonic suppression	> 70 dB
Intermodulation products	< 1 μW
Remote control via serial interface	V.24/RS232C
BITBUS interface	optional

**Environmental Conditions:**

Ambient temperature	performance data guaranteed	between – 5...+45°C
	operational	between –10...+55°C
	storage	between –20...+70°C
Humidity	class F according to DIN 40040	≤ 95 %
	annual mean	≤ 75 %
Installation height		≤ 3000 m

**Power Supply:**

Mains	3/N/PE ~ 400 V	±10 %, 47 to 70 Hz
Power consumption at 2,5 kW RF power		≤ 4 kVA
Power factor cos φ		≥ 0.9

**Dimensions:**

height (without blowers)	2000 mm
width	600 mm
depth	1000 mm

The transmitter fulfils the safety regulations for radio transmitters according to DIN VDE 0866 (EN 60215).

The exciter's technical data are defined in the separate data sheet of transmitter T 3270.

**TRANSRADIO FM Transmitters**

**a secure investment into the future**

Contacts: TRANSRADIO SenderSysteme Berlin AG, Mertensstr. 63, 13587 Berlin  
 Telephone +49 30 33978 0  
 FAX +49 30 33978 599  
 e-mail info@tsb-ag.de  
 Internet http://www.transradio.de

Illustrations not binding for delivery